

NOTES:

1. BUSHING IS IMPREGNATED WITH OIL
2. ALL EXPOSED SURFACES HAVE BLACK OXIDE

MS NO.

NSN NO.

DRAWING NO.

CSFH-44-A

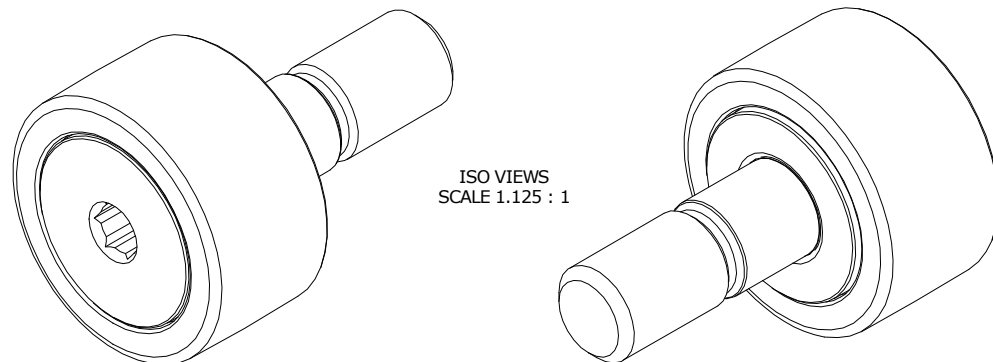

ISO VIEWS  
SCALE 1.125 : 1

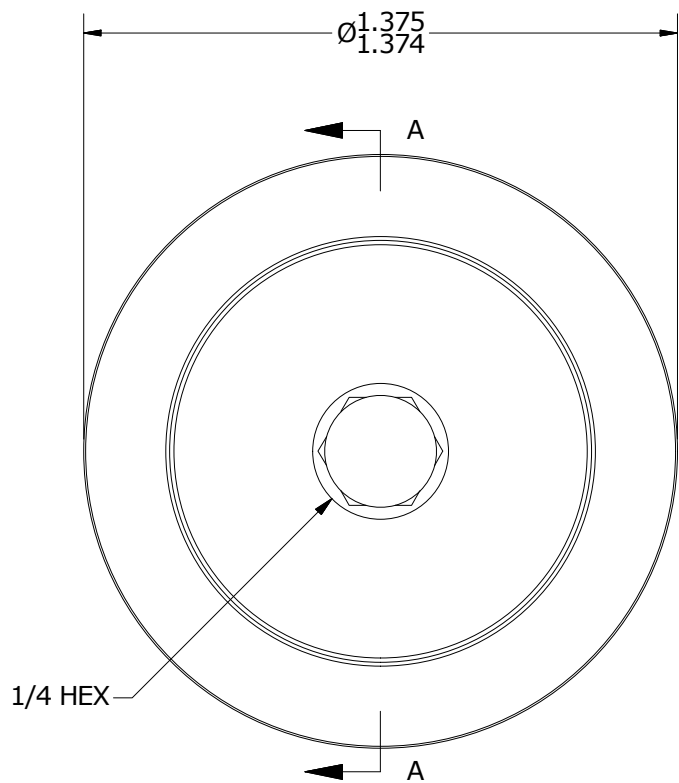

END VIEW  
SCALE 2.25 : 1

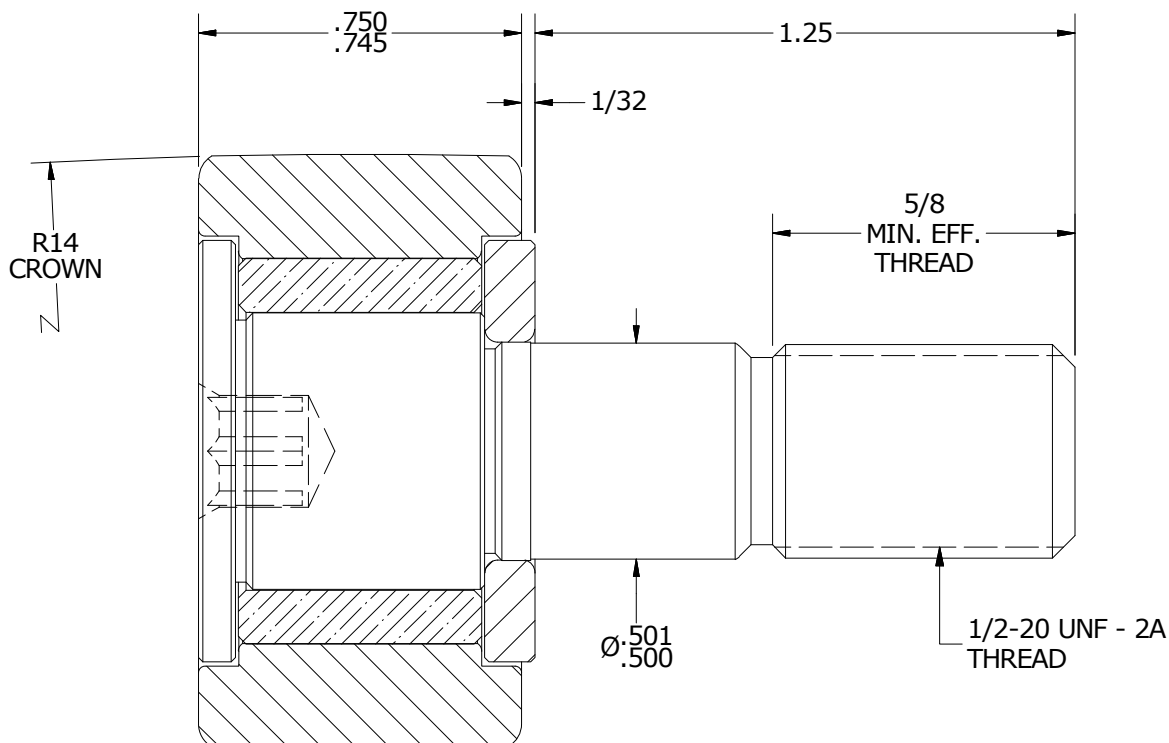

SECTION A-A  
SCALE 2.25 : 1

MATERIAL NOTES:

- OUTER RING - BEARING STEEL, HEAT TREATED
- STUD - STEEL
- WASHER - BEARING STEEL, HEAT TREATED
- BUSHING - SINTERED BRONZE

CUSTOMER PART#

XX = ± .01  
XXX = ± .005  
XXXX = ± .0005  
ANGLES = ± 1'  
INCH [METRIC]  
FRACTION = ± 1/32

CARTER MANUFACTURING IS  
NOT RESPONSIBLE FOR  
TYPOGRAPHICAL ERRORS

**CARTER MANUFACTURING CO., INC.**

GRAND HAVEN, MICHIGAN 49417

ENGINEERING CHANGE ORDER NOTE

REVISION

PART NAME: ASSEMBLY

PRODUCT TYPE: CSFH

**A**

AUTHOR BY  
HG

DRAWN BY  
MD

CHK'D BY  
SGW

SALES  
NC

MATERIAL  
NOTED

REVISION BY  
MD

DATE  
11/29/2018

DATE  
11/28/2018

DATE  
11/29/2018

DATE  
11/29/2018

SHEET  
1 OF 2