

RECOMMENDED MOUNTING HOLE Ø		
Limit	Inch	mm
MIN	.8750	22.2250
MAX	.8755	22.2377

MAXIMUM CLAMPING TORQUE**	
Inch lbf	Nm
750	84.74

- NOTES:
- BUSHING IS IMPREGNATED WITH CARTER STANDARD NEVERLUBE LUBRICANT.
 - ALL EXPOSED SURFACES HAVE BLACK OXIDE.
 - CUSTOM LASER ETCHING IS AVAILABLE UPON REQUEST.

MS NO. _____ NSN NO. _____ DRAWING NO. CSFH-72-A

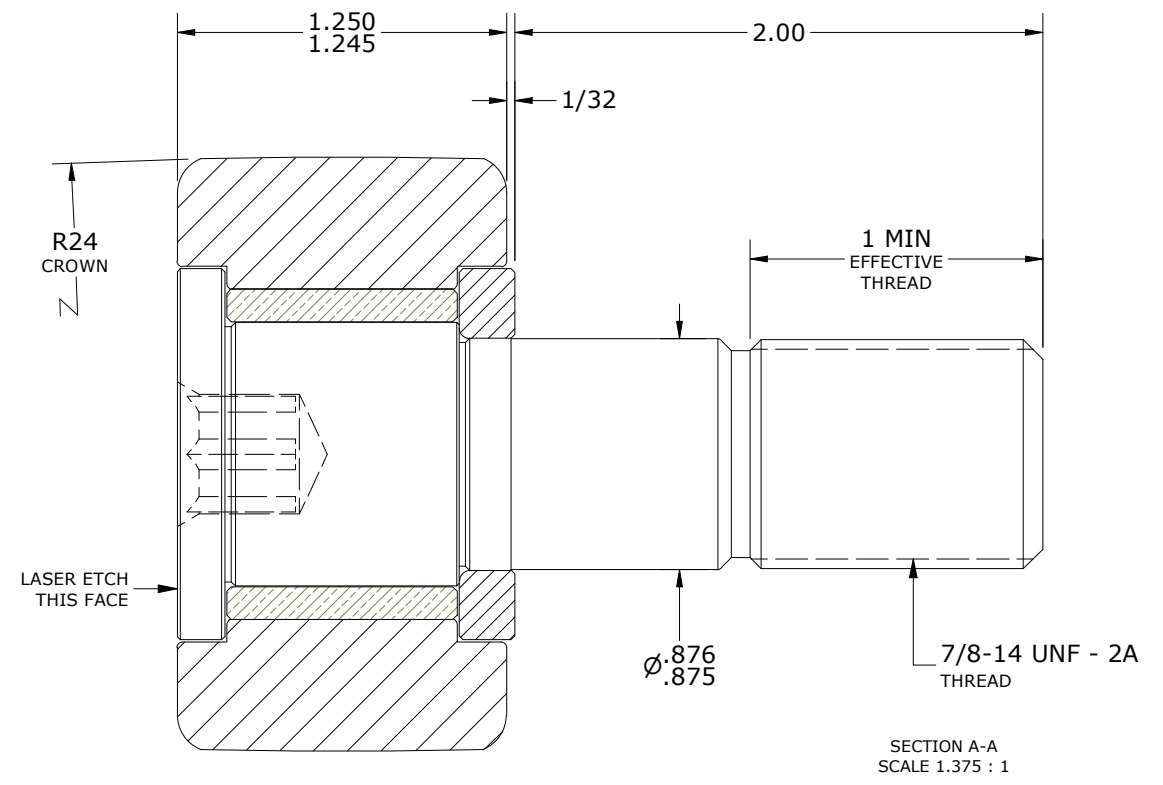
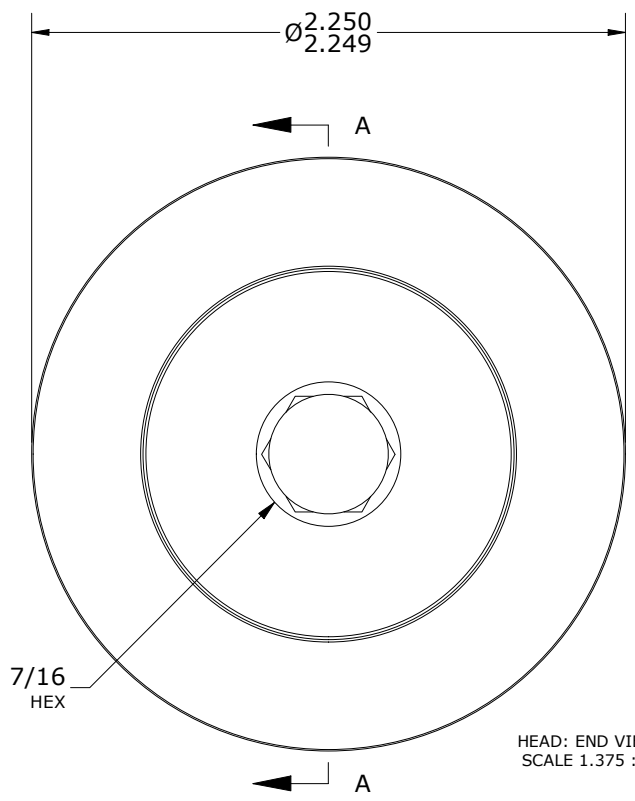
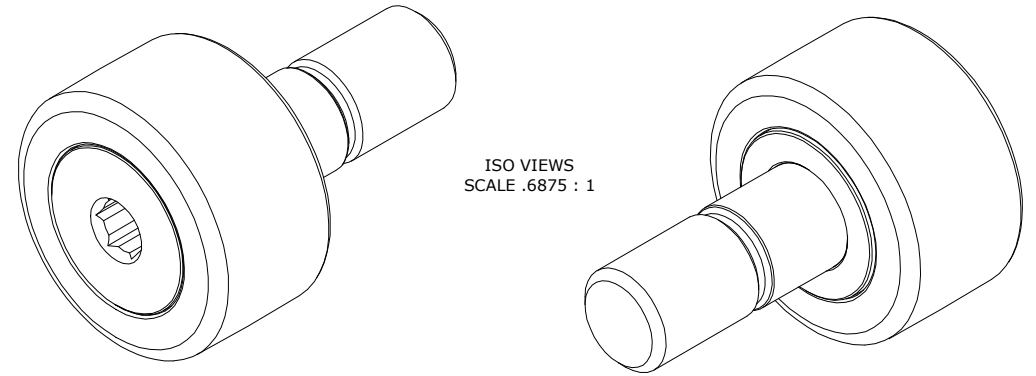

**TORQUE SPECIFICATION IS BASED ON LUBRICATED THREADS, IF USING DRY THREADS DOUBLE TORQUE VALUE.

MATERIAL NOTES:

OUTER RING - BEARING STEEL, HEAT TREATED
 STUD - STEEL
 BUSHING - SINTERED BRONZE
 WASHER - BEARING STEEL, HEAT TREATED

CUSTOMER PART#	XX = ± .01 XXX = ± .005 XXXX = ± .0005 ANGLES = ± 1' INCH [METRIC] FRACTION = ± 1/32
ENGINEERING CHANGE ORDER NOTE	

CARTER MANUFACTURING IS NOT RESPONSIBLE FOR TYPOGRAPHICAL ERRORS				CARTER MANUFACTURING CO., INC. GRAND HAVEN, MICHIGAN 49417			
REVISION		PART NAME: ASSEMBLY			PRODUCT TYPE: CSFH		
A	AUTHOR BY HG	DRAWN BY SGW	CHK'D BY MD	SALES NC	MATERIAL NOTED		
REVISION BY SGW	DATE 5/29/2020	DATE 5/29/2020	DATE 5/29/2020	DATE 5/29/2020	SHEET 1 OF 2		