

LOAD RATINGS	
RATING	Lbs
RADIAL BASIC DYNAMIC	14,270
STATIC THRUST LOAD	12,000
MAXIMUM STATIC CAPACITY	20,000

- NOTES:
1. BEARING IS PACKED WITH NLGI GRADE 2, LITHIUM BASED GREASE (UNLESS OTHERWISE SPECIFIED)
 2. ALL EXPOSED SURFACES HAVE BLACK OXIDE
 3. CUSTOM LASER ETCHING IS AVAILABLE UPON REQUEST

MS NO. NSN NO. DRAWING NO. VHRE-550-A

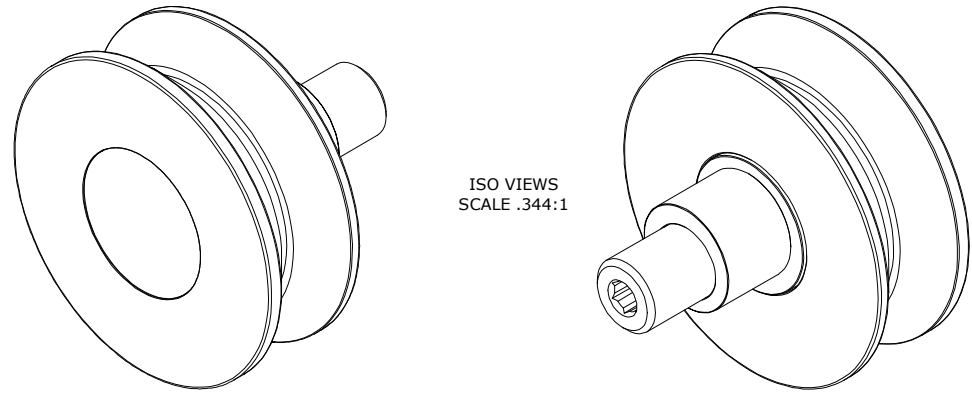

ISO VIEWS
SCALE .344:1

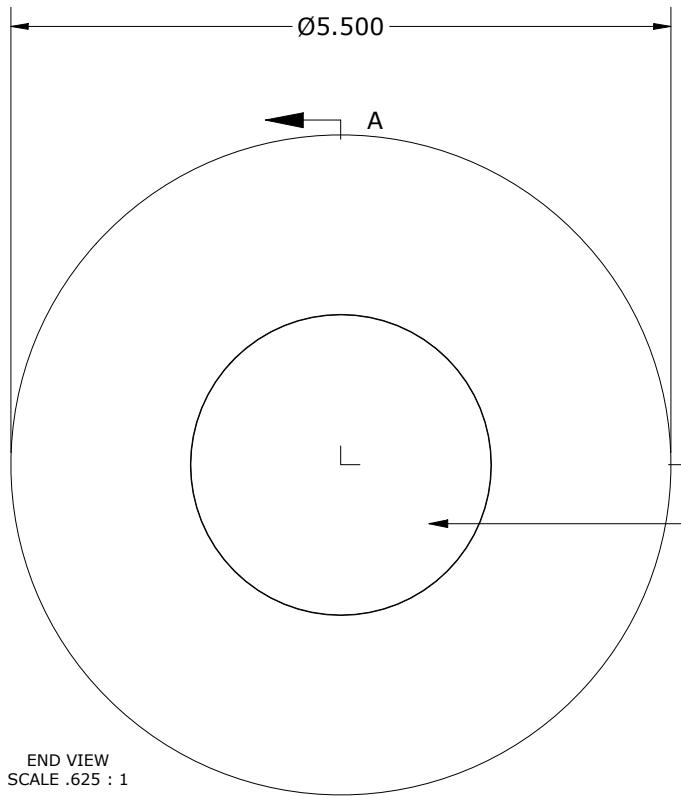

END VIEW
SCALE .625 : 1

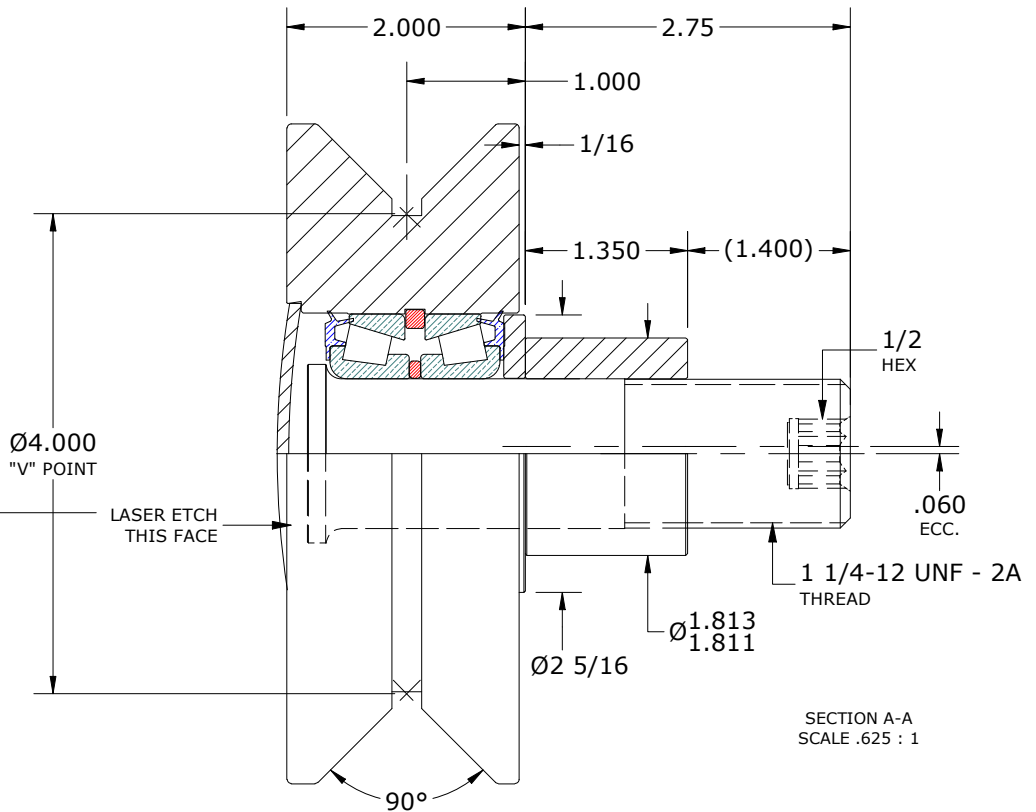

SECTION A-A
SCALE .625 : 1

MATERIAL NOTES:

- OUTER ROLLER HOUSING - BEARING STEEL, HEAT TREATED
- STUD - STEEL
- BEARING ASSEMBLY - LM67000LA-902A2
- WASHER - STEEL
- END CAP - STEEL
- ECCENTRIC SLEEVE - STEEL

CUSTOMER PART#

XX = ± .01
XXX = ± .005
XXXX = ± .0005
ANGLES = ± 1'
INCH [METRIC]
FRACTION = ± 1/32

CARTER MANUFACTURING IS NOT RESPONSIBLE FOR TYPOGRAPHICAL ERRORS

CARTER MANUFACTURING CO., INC.

GRAND HAVEN, MICHIGAN 49417

ENGINEERING CHANGE ORDER NOTE

REVISION

PART NAME: ASSEMBLY

PRODUCT TYPE: VHRE

A

AUTHOR BY

DRAWN BY

CHK'D BY

SALES

MATERIAL

HG

SGW

MD

NC

NOTED

REVISION BY

DATE

DATE

DATE

DATE

SHEET

SGW

6/29/2021

6/28/2021

6/29/2021

6/29/2021

1 OF 2